



PRODUCT FEATURES

电气特性:

- 1200V FS+Trench
1200V 沟槽栅/场终止工艺
- Low Switching Loss
低开关损耗
- Short-Circuit Duration
短路耐量: 10μS
- Positive Temperature Coefficient
正温度系数

APPLICATIONS

典型应用:

- Inverter Welding Machine
逆变焊机
- Induction Heating
感应加热
- High Frequency Switching Power Supply
高频开关电源

Equivalent Circuit and Package

A2 Series

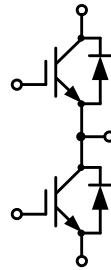

最大额定值 / Maximum Ratings

Parameter	Conditions	Symbol	Value	Unit
集电极-发射极电压 Collector-Emitter voltage	$T_{vj}=25^{\circ}\text{C}$	V_{CES}	1200	V
连续集电极直流电流 Continuous DC collector current	$T_C=100^{\circ}\text{C}, T_{vj\max}=175^{\circ}\text{C}$	$I_{C\text{nom}}$	75	A
集电极重复峰值电流 Repetitive peak collector current	$t_p=1\text{ ms}$	I_{CRM}	150	A
总功率损耗 Total power dissipation	$T_C = 25^{\circ}\text{C}, T_{vj\max} = 175^{\circ}\text{C}$	P_{tot}	395	W
栅极-发射极电压 Gate emitter voltage		V_{GE}	± 20	V

特征值 / Characteristic Values

Parameter	Conditions	Symbol	Value			Unit
			Min.	Typ.	Max.	
集电极-发射极饱和电压 Collector-Emitter saturation voltage	$V_{GE}=15\text{V}, I_C=75\text{A}$ $V_{GE}=15\text{V}, I_C=75\text{A}$ $V_{GE}=15\text{V}, I_C=75\text{A}$	$T_{vj}=25^{\circ}\text{C}$ $T_{vj}=125^{\circ}\text{C}$ $T_{vj}=150^{\circ}\text{C}$	V_{CESat}	2.05 2.45 2.55	2.50	V
栅极-发射极阈值电压 Gate-Emitter threshold voltage	$I_C = 2.6\text{mA}, V_{GE} = V_{CE}$	$T_{vj}=25^{\circ}\text{C}$	$V_{GE(th)}$	5.55	6.15	6.75
栅电荷 Gate charge	$V_{GE}=-15\text{V}\dots+15\text{V}$		Q_G	0.55		μC
内部栅极电阻 Internal gate resistor			R_{Gint}	7.30		Ω
输入电容 Input capacitance	$f=1\text{MHz}, V_{CE}=25\text{V}, V_{GE}=0\text{V}$	$T_{vj}=25^{\circ}\text{C}$	C_{ies}	4.48		nF

特征值 / Characteristic Values

反向传输电容 Reverse transfer capacitance			C_{res}		0.22	
集电极-发射极截止电流 Collector-emitter cut-off current	$V_{CE}=1200V, V_{GE}=0V$	$T_{vj}=25^{\circ}C$	I_{CES}		1	mA
栅极-发射极漏电流 Gate-emitter leakage current	$V_{CE}=0V, V_{GE}=20V$	$T_{vj}=25^{\circ}C$	I_{GES}		100	nA
开通延迟时间 Turn-on delay time	$I_C=75A, V_{CE}=600V$ $V_{GE}=\pm 15V, R_G=1.8\Omega$ (电感负载) / (inductive load)	$T_{vj}=25^{\circ}C$ $T_{vj}=125^{\circ}C$ $T_{vj}=150^{\circ}C$	t_{don}		140 154 170	ns
上升时间 Rise time	$I_C=75A, V_{CE}=600V$ $V_{GE}=\pm 15V, R_G=1.8\Omega$ (电感负载) / (inductive load)	$T_{vj}=25^{\circ}C$ $T_{vj}=125^{\circ}C$ $T_{vj}=150^{\circ}C$	t_r		115 132 178	
关断延迟时间 Turn-off delay time	$I_C=75A, V_{CE}=600V$ $V_{GE}=\pm 15V, R_G=1.8\Omega$ (电感负载) / (inductive load)	$T_{vj}=25^{\circ}C$ $T_{vj}=125^{\circ}C$ $T_{vj}=150^{\circ}C$	t_{doff}		143 160 200	
下降时间 Fall time	$I_C=75A, V_{CE}=600V$ $V_{GE}=\pm 15V, R_G=1.8\Omega$ (电感负载) / (inductive load)	$T_{vj}=25^{\circ}C$ $T_{vj}=125^{\circ}C$ $T_{vj}=150^{\circ}C$	t_f		150 170 230	
开通损耗能量 (每脉冲) Turn-on energy loss per pulse	$I_C=75A, V_{CE}=600V$ $V_{GE}=\pm 15V, R_G=1.8\Omega$ (电感负载) / (inductive load)	$T_{vj}=25^{\circ}C$ $T_{vj}=125^{\circ}C$ $T_{vj}=150^{\circ}C$	E_{on}		6.23 9.51 10.04	mJ
关断损耗能量 (每脉冲) Turn-off energy loss per pulse	$I_C=75A, V_{CE}=600V$ $V_{GE}=\pm 15V, R_G=1.8\Omega$ (电感负载) / (inductive load)	$T_{vj}=25^{\circ}C$ $T_{vj}=125^{\circ}C$ $T_{vj}=150^{\circ}C$	E_{off}		3.22 6.57 6.76	
短路数据 SC data	$V_{GE}\leq 15V, V_{CC}=800V$ $V_{CEmax}=V_{CES}-L_{sCE}\cdot di/dt$ $t_p\leq 10\mu s, T_{vj}=150^{\circ}C$		I_{SC}		390	A
结-外壳热阻 Thermal resistance, junction to case	每个 IGBT / per IGBT		R_{thJC}		0.38	K/W
在开关状态下温度 Temperature under switching conditions			$T_{vj op}$	-40	150	$^{\circ}C$

Diode 最大额定值 / Maximum Ratings

Parameter	Conditions	Symbol	Value	Unit
反向重复峰值电压 Repetitive peak reverse voltage	$T_{vj}=25^{\circ}C$	V_{RRM}	1200	V
连续正向直流电流 Continuous DC forward current		I_F	75	A
正向重复峰值电流 Repetitive peak forward current	$t_p=1ms$	I_{FRM}	150	A
I^2t 值 I^2t -value	$t_p=10ms, \sin 180^{\circ}, T_j=125^{\circ}C$	I^2t	1200	A^2s

Diode 特征值 / Characteristic Values

Parameter	Conditions	Symbol	Value			Unit
			Min.	Typ.	Max.	
正向电压 Forward voltage	$I_F=75A, V_{GE}=0V$ $I_F=75A, V_{GE}=0V$ $I_F=75A, V_{GE}=0V$	$T_{vj}=25^\circ C$ $T_{vj}=125^\circ C$ $T_{vj}=150^\circ C$	V_F	2.05 1.70 1.60	2.50	V
反向恢复峰值电流 Peak reverse recovery current	$I_F=75A,$ $-di_F/dt=1696A/\mu s(T_{vj}=150^\circ C)$ $V_R=600V, V_{GE}=-15V$	$T_{vj}=25^\circ C$ $T_{vj}=125^\circ C$ $T_{vj}=150^\circ C$	I_{RM}	124 131 139		A
恢复电荷 Recovered charge	$I_F=75A,$ $-di_F/dt=1696A/\mu s(T_{vj}=150^\circ C)$ $V_R=600V, V_{GE}=-15V$	$T_{vj}=25^\circ C$ $T_{vj}=125^\circ C$ $T_{vj}=150^\circ C$	Q_r	11.5 25.0 37.0		μC
反向恢复损耗（每脉冲） Reverse recovered energy	$I_F=75A,$ $-di_F/dt=1696A/\mu s(T_{vj}=150^\circ C)$ $V_R=600V, V_{GE}=-15V$	$T_{vj}=25^\circ C$ $T_{vj}=125^\circ C$ $T_{vj}=150^\circ C$	E_{rec}	0.40 2.11 2.16		mJ
结-外壳热阻 Thermal resistance, junction to case	每个二极管 / per diode		R_{thJC}		0.58	K/W
在开关状态下温度 Temperature under switching conditions			$T_{vj op}$	-40	150	$^\circ C$

模块 / Module

Parameter	Conditions	Symbol	Value			Unit
绝缘测试电压 Isolation test voltage	RMS, f=50Hz, t=1min	V_{ISOL}	4000			V
内部绝缘 Internal isolation			Al ₂ O ₃			
储存温度 Storage temperature		T_{stg}	-40		125	$^\circ C$
模块安装的扭矩 Mounting torque for modul mounting		M	3.0		6.0	Nm
重量 Weight		W		155		g



图 1. 典型输出特性 ($V_{GE}=15V$)
Figure 1. Typical output characteristics ($V_{GE}=15V$)



图 2. 典型输出特性 ($T_{vj}=150^{\circ}C$)
Figure 2. Typical output characteristics ($T_{vj}=150^{\circ}C$)

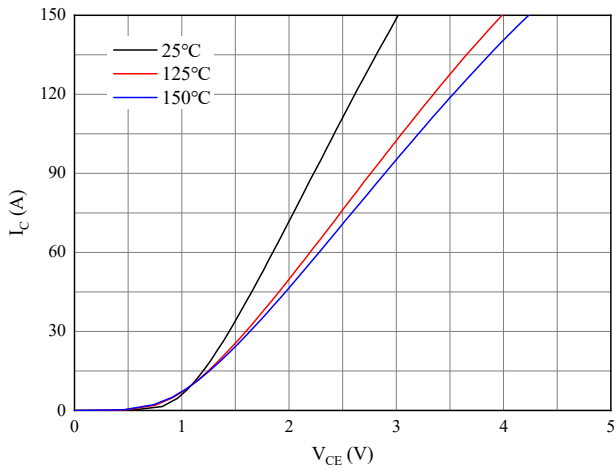

图 3. 典型传输特性 ($V_{CE}=20V$)
Figure 3. Typical transfer characteristic ($V_{CE}=20V$)

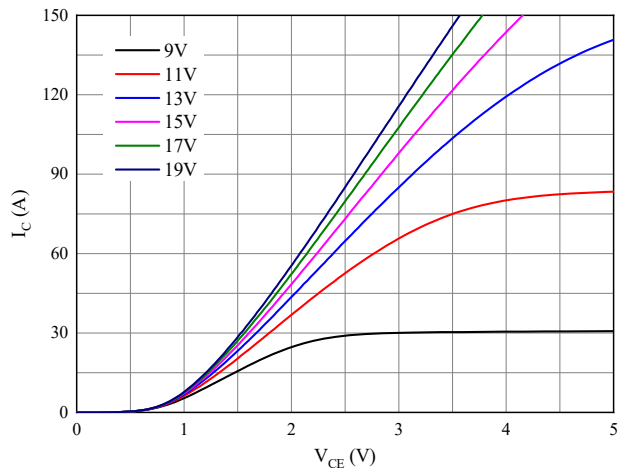

图 4. 正向偏压特性 二极管
Figure 4. Forward characteristic of Diode

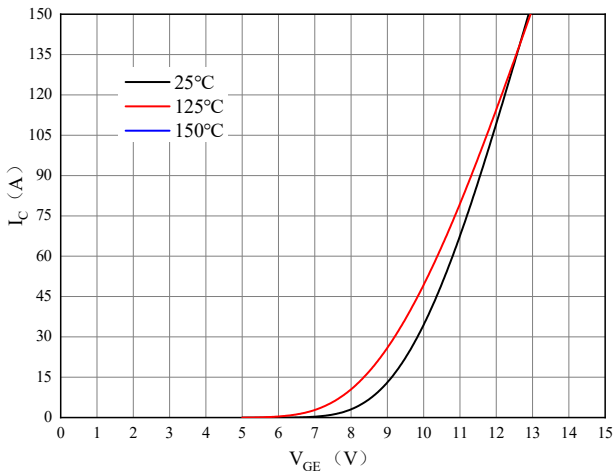

图 5. 开关损耗 逆变器
Figure 5. Switching losses of IGBT
 $V_{GE}=\pm 15V, R_{Gon}=15\Omega, R_{Goff}=15\Omega, V_{CE}=600V$

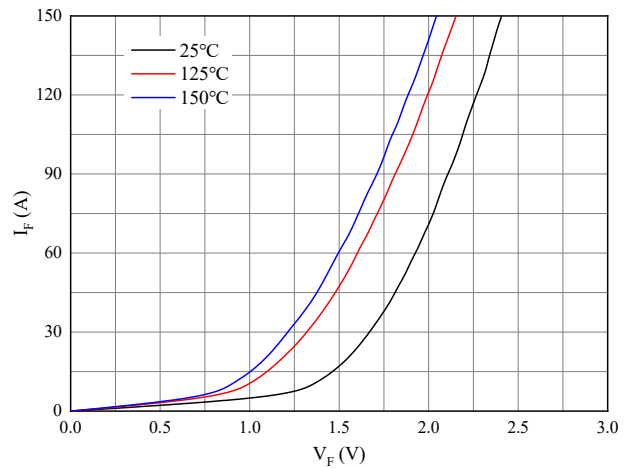

图 6. 开关损耗 逆变器
Figure 6. Switching losses of IGBT
 $V_{GE}=\pm 15V, I_C=50A, V_{CE}=600V$

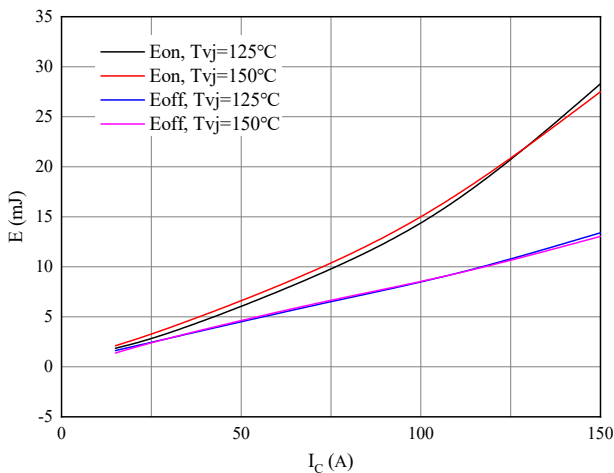

图 7. 开关损耗 二极管
Figure 7. Switching losses of Diode
 $R_{Gon}=2\Omega, V_{CE}=600V$

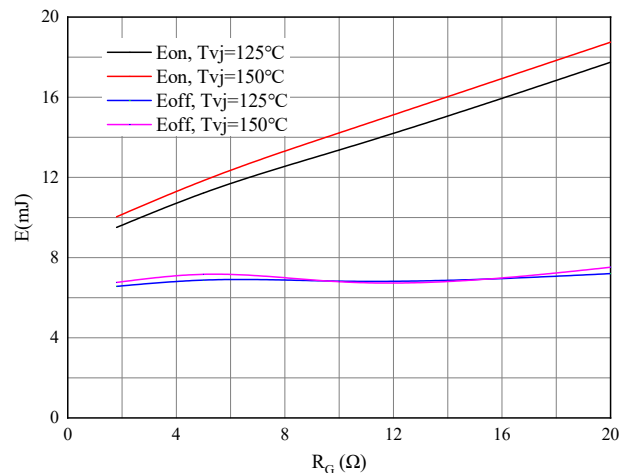

图 8. 开关损耗 二极管
Figure 8. Switching losses of Diode
 $I_F=100A, V_{CE}=600V$

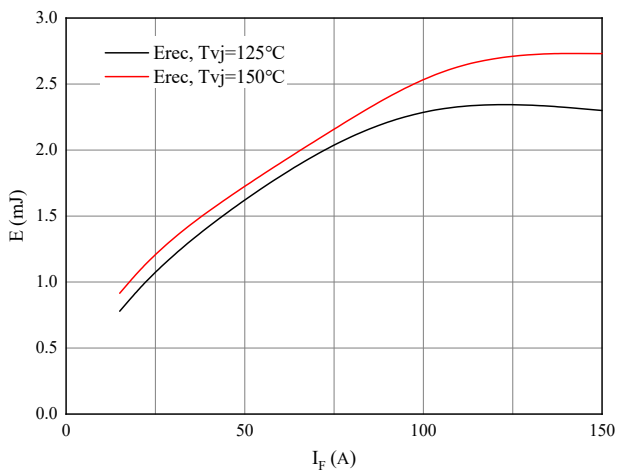

图 9. 电容特性
Figure 9. Capacitance characteristic

接线图 / Circuit diagram

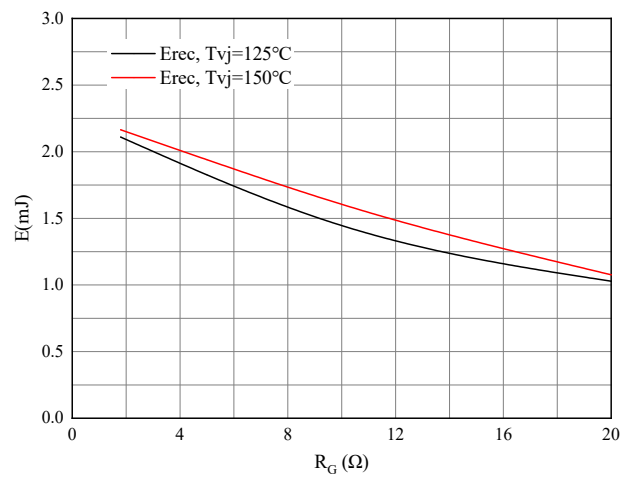

封装尺寸 / Package outlines

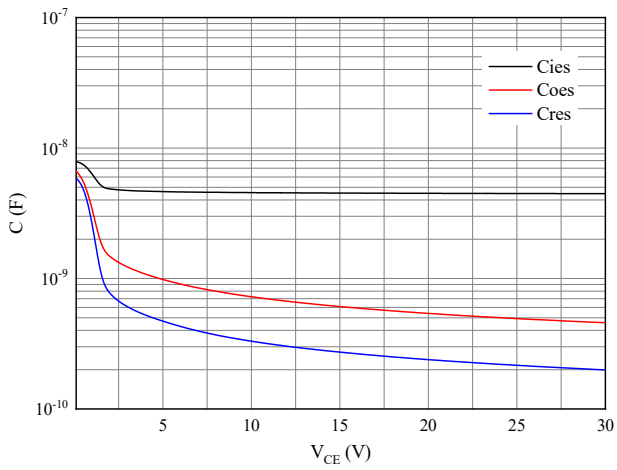
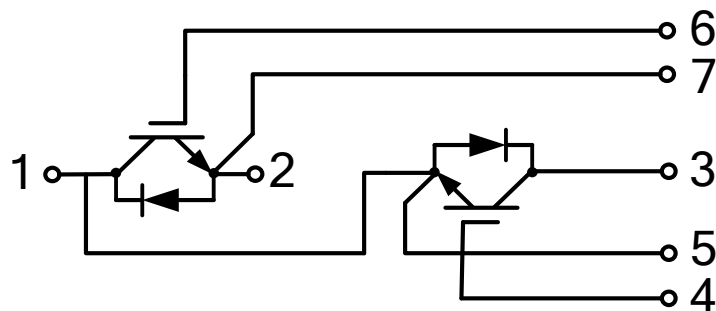
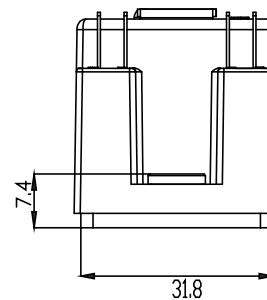
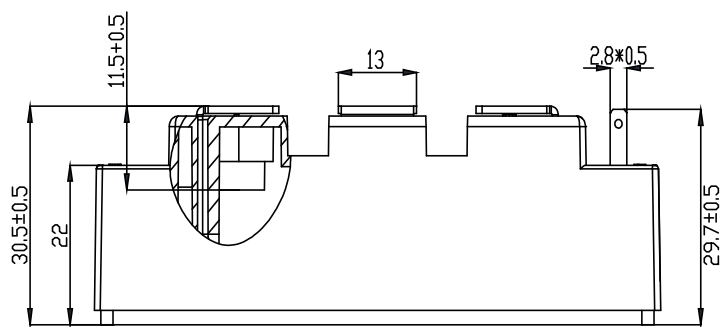
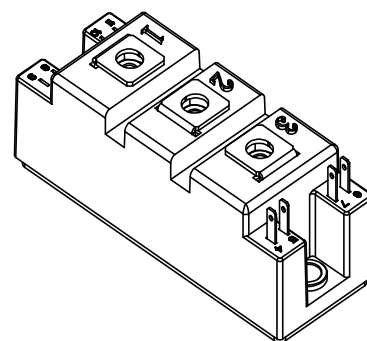
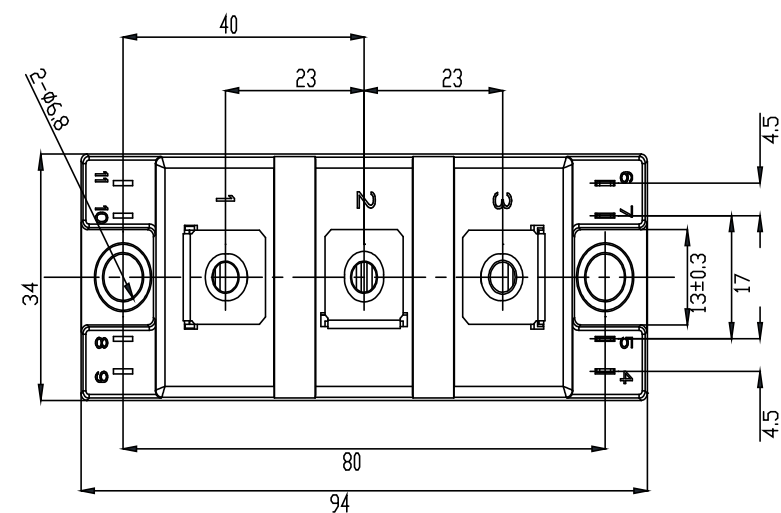

Unit:mm